

Aug. 12, 1952

H. L. CHAPMAN
BOTTLE CARRIER

2,606,702

Filed Jan. 9, 1948

2 SHEETS—SHEET 2

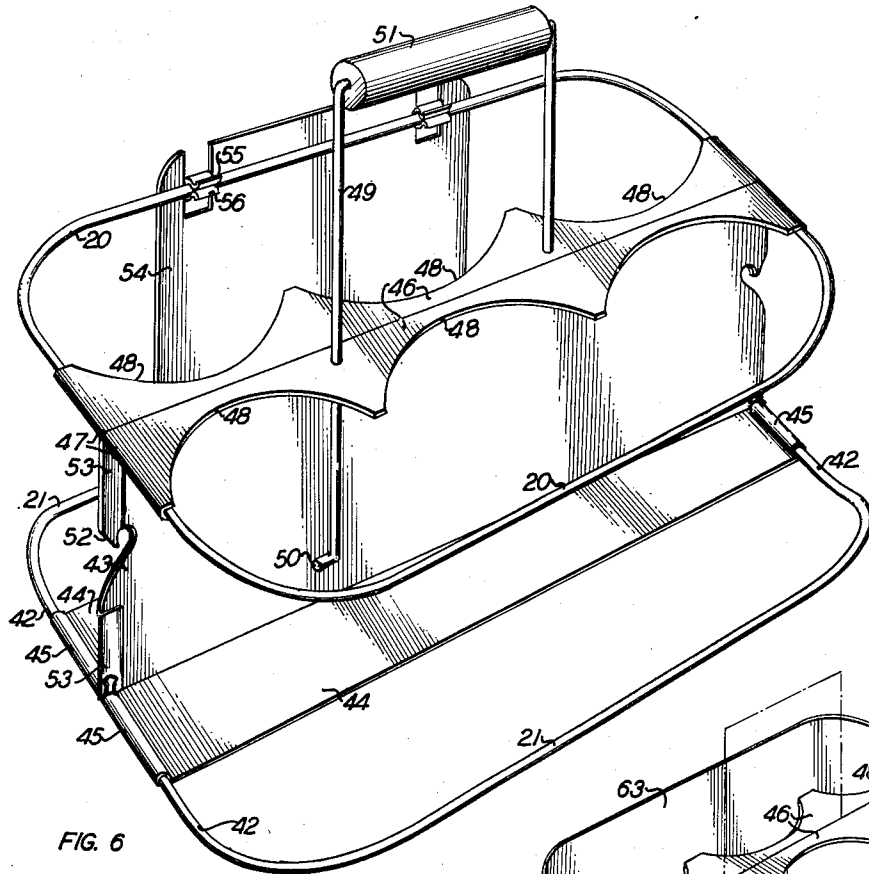

FIG. 6

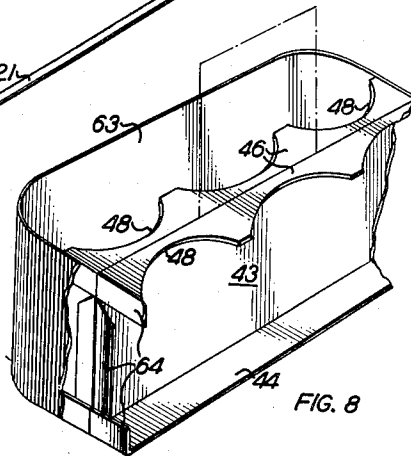

FIG. 8

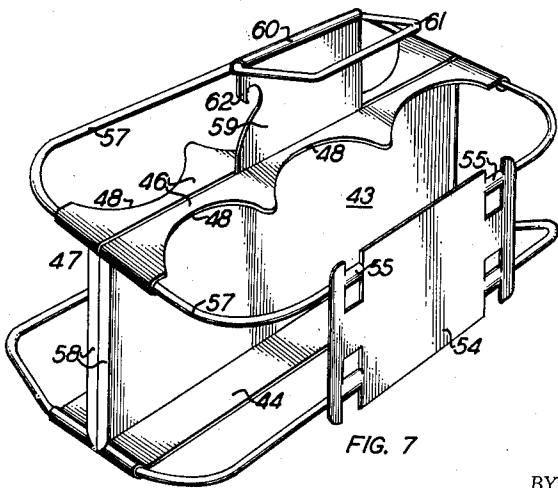

FIG. 7

INVENTOR
H. L. CHAPMAN

BY

Hyatt Dowell
ATTORNEY

UNITED STATES PATENT OFFICE

2,606,702

BOTTLE CARRIER

Harold L. Chapman, East Moriches, N. Y.

Application January 9, 1948, Serial No. 1,338

2 Claims. (Cl. 224—48)

1

This invention relates to article handling, and more particularly to the handling of relatively small articles such as bottles or the like used for soft drinks or other beverages.

The invention is specifically directed to a carrier or container for holding two substantially parallel rows of bottles with ordinarily three bottles in each row.

The handling of bottles containing soft drinks or other beverages in substantial volume has presented a problem from various angles. Therefore it is an object of the invention to provide a solution of such problems including an inexpensive, simple, compact, convenient, carrier, capable of being stacked compactly when filled with bottles, with the bottles supported adequately reducing probability of breakage, and preventing their rattling and being damaged by their rubbing together or by contact with other objects.

Another object of the invention is to provide a combination carrier constructed of wire and flat metal members and a handle which can be readily detached and replaced, and which is constructed of a minimum of material.

A further object of the invention is to provide a carrier which will enhance the display of the articles and one which is an improvement over my Patent 2,375,467 granted May 8, 1945.

Further objects and advantages of the invention will be apparent from the following description taken in conjunction with the accompanying drawings, wherein:

Fig. 1 is a perspective illustrating one application of the invention;

Fig. 2, a detail certain of the parts in bottle neck engaging position;

Fig. 3, a perspective of a modified form of combination handle and bottle neck engaging member;

Fig. 4, a perspective of a modified and simplified handle;

Fig. 5, a fragmentary detail of a sheet metal bottle separating member susceptible of use in lieu of the corresponding wire member of Fig. 1;

Fig. 6, a modified form of bottle carrier;

Fig. 7, a further modified form; and

Fig. 8, a further modified form.

Referring to the drawings in detail, the bottle case or carrier of my Patent 2,375,467 includes features which are susceptible of improvement. For example the device may be made of a combination of rod and flat metal members, may be simpler of construction, includes minimum parts, and requires less labor and equipment in its pro-

2

duction and therefore is less expensive to produce.

The present invention, as previously indicated, is directed to a more practical commercially feasible structure than that of my patent. It comprises a combination carrier of wire and flat metal members which afford vertical and horizontal support for the bottles or other articles contained within the same. The horizontal support is located at the intermediate portion of the carrier for the bottles or other articles and the structure is also susceptible of being carried with ease by a handle pivotally connected to the body of the device so that the proper equilibrium is maintained. The handle may serve to engage the necks of the bottles and hold them against rattling.

Referring particularly to Fig. 1 longitudinal or horizontal base members 10 and 11 provide vertical supports for two rows of bottles or other articles not shown. The base member 10 has its ends 12 and 13 bent upwardly and merging into or forward, along with corresponding ends 14 and 15 of the base member 11, to relatively flat apex pivot holders 16 and 17. The pivot holders 16 and 17 are provided with central pivot receiving apertures 18 and 19. The suspension portion of the carrier is thus provided and is of an underslung character, or is located beneath the other parts of the device as well as beneath the bottles or articles carried.

Horizontal retention and supporting means is provided in the form of upper and lower generally rectangular rod members 20 and 21 respectively. These are secured in any desired manner, as by welds 22, to the ends 12, 13, 14 and 15, with the upper rectangular rod member at the proper height for engaging the bottles at their intermediate portions and a substantial distance from their bottoms. Correspondingly the lower rectangular rod member is located close to the lower ends of the bottles.

In order to maintain the bottles of one row separate from the bottles of the other row a lower separator 23 is secured by welds 24 longitudinally between the end portions of the generally rectangular rod member 21. Also, an upper separator is provided for a similar purpose. As shown in Fig. 1, this upper separator consists of wire members 25 and 26 secured by welds 27 at their ends to the rectangular rod member 20. These separator members 25 and 26 are preferably bent to outwardly present curved portions which conform to the surfaces of the three bottles contained in each side of the carrier.

Also, in lieu of the upper separator of two oppositely bent wire rods just described, an upper

3

separator 28 of sheet metal may be provided, it being understood that either may be employed with the structure of Fig. 1 and further that in lieu of the separator 28 a longitudinal dividing separator may be employed corresponding to that shown in Figs. 6, 7 and 8, hereinafter more fully described.

A movable handle member consisting of a wire frame 29 is mounted in the upper portion of the device by means of pivots 30 and 31. It is provided with a hand grip 32 which is adapted to be grasped in order to carry the device from one place to another with the hand grip in the position shown in Fig. 1. The frame 29 is provided with curved portions 33, three on each side, which are adapted to engage and hold the neck of bottles when the frame is in horizontal position at right angles to the position of Fig. 1.

Instead of the frame 29 and hand grip 32 a similar member 35 of sheet metal may be employed. It also has a hand grip 36 with extremities 37 forming bottle openers and curved bottle neck engaging portions 38. The extremities of the metal member 35 may be curled up to provide pivots 39 at each end of the device.

Instead of the frame 29 and sheet metal 35 a bale or handle member 40 may be provided having a hand grip 41.

In the preceding figures the carriers have consisted primarily of wire with some flat metal portions. However, if desired, as shown in Figs. 6, 7, and 8, the flat metal portions may be increased and the wire or rod portions decreased. Referring particularly to Fig. 6 horizontal retention and supporting means are employed which correspond to the upper and lower generally rectangular rod members 20 and 21 of Fig. 1. However, the lower members 21 are additionally provided with curved portions 42 so that the side portions of the rectangular members are disposed in a plane slightly higher in elevation than the intermediate end portions of the rod members.

A pair of metal members 43 are placed back to back and have lower shelf portions 44 with curved ends 45 snugly encircling the end portions of the rod member 21. The shelf portions 44 serve to engage the bottoms of the bottles and support the same. The metal members 43 have horizontal portions 46 provided with curved ends 47 which snugly engage the rod members 20 and said horizontal portions 46 are also provided with oppositely disposed edges 48 of a configuration to conform to the curvature of the bottles carried. Thus the main body of the device consists of upper and lower generally rectangular rod members and two sheet metal members back to back.

A simple U-shaped bail 49 of wire or rod stock may have its extremities provided with right angular bends or right angular portions 50 so that the bail may be employed as a handle with or without a hand grip 51.

If desired the metal members 43 may have can opening portions 52 and in order to fasten the two members together lips 53 may be employed with or without spot or other types of welds between the two members.

For the two-fold purpose of providing advertising space and as a reinforcement supporting plates 54 may be employed, each plate having upper and lower struck-out portions 55 and 56 which in opposed position form a clamp for engaging the upper and lower rod members 20 and 21, each plate being provided with a plurality of such clamping portions. With the structure just described the bail 49 may be pushed down to a

4

position beneath the height to which the bottles extend when the bottles are in the carrier and thus the filled carriers can be compactly stacked.

The structure of Fig. 7 is similar to that of Fig. 6 except that instead of having a pair of rectangular frame members 20 and 21 a continuous rod member 57 having upper and lower horizontal portions is used at each side of the device and with the intermediate portion thereof enclosed by sheet metal encircling portions 58 which are the end portions of the opposed sheet metal members 43. Also instead of the bail 49 a sheet metal handle member 59 may be employed with an encircling portion 60 housing a rectangular handle 61, the sheet metal member 59 being rigidly held in position by means of spot welds, or other suitable fastening means not shown. The flat member may likewise be provided with a bottle opener 62.

In Fig. 8 is shown a slightly modified construction which may employ a handle corresponding to that of either of Figs. 6 and 7. Otherwise the device consists of a rectangular retaining member 63 and opposed members 43. The upper and lower edges of the rectangular member 63 perform the functions of the upper and lower rectangular rod members 20 and 21 and the intermediate portion between its upper and lower edges provides for the reception of matter to be displayed and to reinforce the edges of the device as well as to enhance its attractiveness. Instead of rolling over the ends of the members 43 flanges 64 may be provided for attachment to the rectangular member 63 for making a solid unitary construction by spot welding or other desired fastening means.

It will be obvious to those skilled in the art that various changes may be made in the invention without departing from the spirit and scope thereof and therefore the invention is not limited by that which is shown in the drawings and described in the specification but only as indicated in the appended claims.

What is claimed is:

1. A bottle carrier comprising a container for two substantially parallel rows of bottles or other objects, including a frame formed of metallic wire members, said frame including members for location beneath and in contact with the bottoms of articles supported, other members disposed at different levels for engaging the sides of articles supported, multiple bottle separating means disposed adjacent the bottom of the device longitudinally of the same, a second bottle separating means disposed above said first separating means and having portions curved in a manner to separate the intermediate portions of the bottles and to conform to each bottle, a wire handle member pivotally supported centrally of the frame and having oppositely disposed curved gripping portions for engagement with the necks of bottles for steadying the same when devices with filled bottles are in a stack or for disposition in upright position in order that the handle may be used in the transportation of the device.

2. A bottle carrier comprising a container with two substantially parallel rows of bottles or other objects, said container being formed of metallic wire members and having portions for location beneath and in contact with articles to be carried and other portions disposed at different levels for engaging the sides of articles carried, multiple bottle separating means disposed adjacent the bottom of the device longitudinally of the same, a second bottle separating means disposed above

said first separating means and having contacting portions curved to conform to the bottles for maintaining the intermediate portions of the bottles in spaced relation, a wire handle member movably supported centrally of the container and having a gripping portion for disposition in different elevations in order for the handle to be used in transporting the device when in one position and to permit the device to be stacked with others when in its other position, said handle member being so constructed that when it is moved to its lower position it will engage certain of the bottles and steady them in the carrier.

HAROLD L. CHAPMAN.

REFERENCES CITED

The following references are of record in the file of this patent:

UNITED STATES PATENTS

Number	Name	Date
2,375,467	Chapman -----	May 8, 1945
2,398,166	Struensee -----	Apr. 9, 1946
2,414,708	Bassichis -----	Jan. 21, 1947
2,420,603	Lee -----	May 13, 1947
2,425,135	Suiter -----	Aug. 5, 1947